



www.omerlift.com

O.ME.R. S.p.a.
Via G. Galilei, 20
30035 Mirano (VE) ITALY
Tel. +39 041 570 0303
Fax +39 041 570 0273

info@omerlift.com



RALLA 25

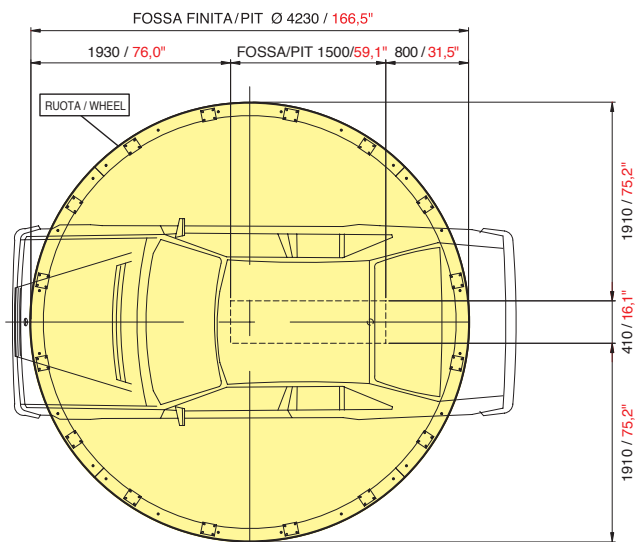
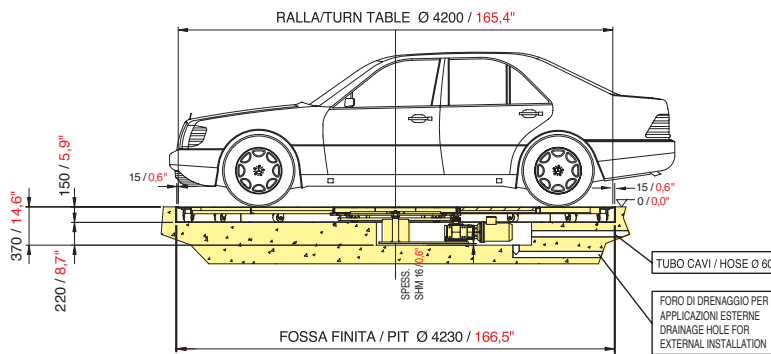

| Portata Capacity Tragfähigkeit Capacité Capacidad | Diametro Diameter Durchmesser Diámetro | Fossa Pit Grube Fosse de roulement Foso | Potenza Electric motor Leistung Puissance Potencia | Alimentazione Power supply Versorgung Alimentation Alimentación | Peso Weight Gewicht Poids Peso | Velocità Speed Geschwindigkeit Vitesse Velocidad |
|---|---|---|--|---|--|--|
| 2.500 kg 5.500 Lbs | Ø 4.200/165,3" | Ø 4.230/166,5" | 1,5 Kw | 230 - 400v/3/50 HZ | 1.300 kg 2.890 lbs | 2 RPM |

| |
|--|
| Opzione per copertura piastrellabile Option for platform tiles application Zur verfügung flachesblech zu fliesen Option pour couverture à carrelers opción para cobertura con baldosas |
| max 70 kg/m ² max 14.5 lbs/square foot |